



AA-SD-RMF

Vandal Resistant Refillable Liquid Foaming Soap Dispenser

**Features:**

- Vandal Resistant Design
- Made in USA
- 10 Year Vandalism Warranty on 12g
- 800ml Refillable Bottle for Significant Savings
- Interior & Exterior Mounting Hole Options
- Stops Bulk Theft of Soap & Sanitizer Product
- Reduces Maintenance Costs
- Spray & Drip Deflective
- Secured with 2X Keyed Cylinder Lock
- Surface Mounted
- Corrosion Resistant
- LEED Sustainable Materials

Dimensions: 8" x 13 7/8" x 4 1/2" (WxHxD)

Weight: 12 lbs - 12 gauge Stainless Steel

Material Options:

- 12-gauge 304L Stainless Steel
- 14-gauge 304L Stainless Steel
- 16-gauge 304L Stainless Steel

Model Names:

- AA-SD-RMF-304L-12g
- AA-SD-RMF-304L-14g
- AA-SD-RMF-304L-16g

Finish: Stainless Steel Satin # 4 Finish

Compatibility: Includes 800mL refillable foaming soap bottle. This bottle can be refilled with any liquid foaming soap of choice such as:

- Clean Revolution Foaming Hand Soap purchased in 4 pack 1 Gallon.

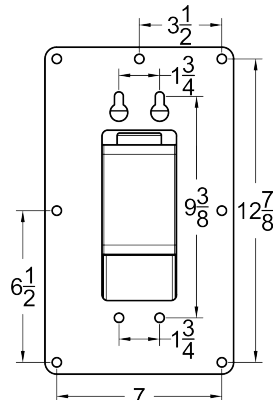
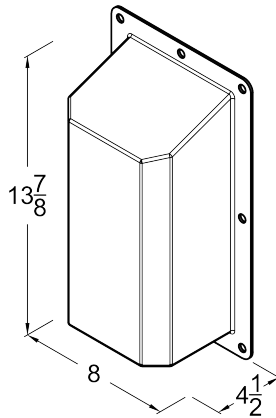

Mounting: 3/8" Surface Mounting Hole Placements. Mounting Hardware is not included due to wide variety of mounting surfaces. Installer must select 3/8" hardware suitable for application. Interior & exterior mounting hole options available but only one type has to be used. Recommended use of Interior Mounting Holes or Security Hardware for Exterior Mounting Holes if theft is a concern.

Installation: Secure fixture to wall with appropriate 3/8" Stainless Steel anchoring hardware (not provided) for optimal installation strength. Recommend 3/4" or greater back bracing for walls. Partitions may require T-nuts or other suitable anchoring devices. When possible it is recommended that units be through bolted back-to-back providing optimal installation strength.

Guide Specification: Dispenser shall be constructed with 12 or 16 gauge 304L or 12 gauge 316L Stainless Steel joined /w TIG welds and edges de-burred. Dispenser shall not be cross-metal contaminated during manufacturing construction. Dispenser housing shall provide protective cover for soap product against drip and spray. Dispenser shall be easily refillable with bulk soap supplies. Dispenser shall have 3/8" mounting holes. 12 Gauge models shall include a 10 vandalism warranty when properly installed & locked while in service. 316L SS shall be used for US Navy maritime use or if exposure to salt water is prevalent.

